

KONTRAC PN50MS / PN60MS Multi-system converter for passenger coaches

*KONTRAC PN50MS / PN60MS
for passenger coaches*

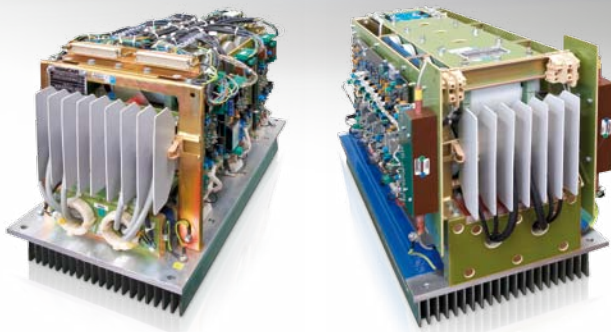

KONTRAC PN50MS / PN60MS is used as the power supply for all consumers in modern air-conditioned coaches on European railways. It is powered by any of four UIC voltages and serves as the source of electric energy for the coach air-conditioning system, all single-phase and three-phase consumers, as well as for charging batteries and power supply of all DC consumers onboard a passenger coach. Switching to another UIC system is performed automatically and without external supervision.



Inverter and high voltage module

Features

- Four input voltages i.e. supply systems
- Microprocessor control and diagnostics
- Input / output galvanic insulation
- Active control of input impedance
- Easy maintenance
- Modular design
- Integrated disconnecting and earthing device
- Flat-battery power supply
- Automatic switching to another input voltage i.e. supply system

KONTRAC PN50MS / PN60MS consists of

- Disconnecting and earthing device
- Input contactor and precharging circuit
- Input filter
- High-voltage modules
- Output inverter modules and a battery charger
- Flat battery power supply
- Air system ventilation
- Control unit

KONTRAC PN50MS / PN60MS

Digital control unit

Digital control unit (DCU) is based on proprietary embedded control platform which has been used for years in our rail solutions (locomotives, coaches, tramways, EMUs, DMUs).

DCU is responsible for all sequence control, regulation, protection, communication, supervision and diagnostics tasks. Special care is put on obsolescence issues, and modularity.

Diagnostic and visualization

Proprietary powerful diagnostic and visualization tool (ZZT) is compatible with all our platforms through many generations of control electronic solutions. Configurable event-driven data logging and event recording is integrated in the control electronics.

Mechanical design and cooling system

The converter is designed for under-floor mounting with IP54 protection. Modular design of the converter allows an easy maintenance access enabling easy replacement of each power module. The increased power density of the power modules enables compact and light-weighted converter design. The converter is efficiently cooled by forced air.

Application example

As a part of a large modernization project of passenger coaches owned by Croatian Railways, couchette coaches of 2nd class have been equipped with multi-system static converter KONTRAC PN60MS. The converter is used as a power supply for air conditioning unit, all single-phase and three-phase consumers, all DC consumers and for charging the coach battery. In this way it significantly contributes to pleasant and comfortable ride to different European destinations.

BASIC TECHNICAL DATA

	PN50MS	PN60MS
Input voltages	1000 V, 16 2/3 (22, 50) Hz, 1500 V, 50 Hz 1500 / 3000 Vdc	
AC outputs	3 x 400 V, 50 Hz, 30 kVA + 22 kVA 3 x 400 / 230 V, 50 Hz, 8 kVA	
DC output	30 VDC, 6 kW	30 Vdc, 12 kW
Cooling	Forced air-cooling	
Size (L x W x H)	2360 x 1900 x 600 mm	2590 x 1900 x 600 mm
Weight	1630 kg	1802 kg
Mounting place	Under-floor	
Connecting interface	CAN / MVB / Ethernet	



Croatian Railways couchette coach equipped with the converter KONTRAC PN60MS

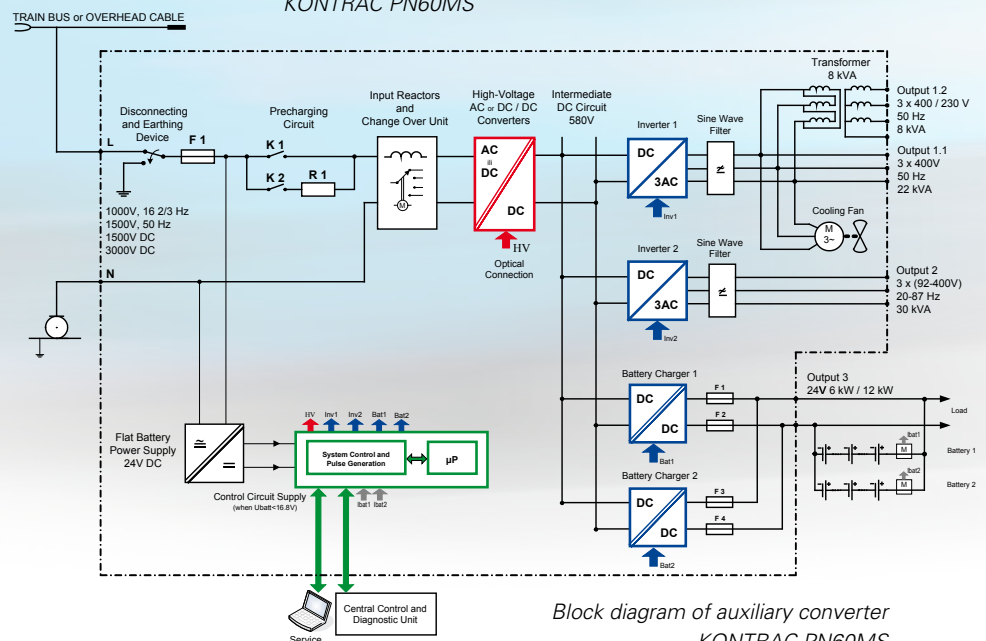

Block diagram of auxiliary converter KONTRAC PN60MS

KONČAR

KONČAR - Electronics and Informatics Inc.

Fallerovo šetalistište 22, 10000 Zagreb, Croatia
 phone: +385 1 3655 599; fax: +385 1 3655 298
 e-mail: transportation@koncar-inem.hr
 www.koncar-inem.hr