

KONTRAC PN6MS Multi-system battery charger for passenger coaches

*KONTRAC PN6MS
for passenger coaches*



KONTRAC PN6MS is a multi-system battery charger which serves as the source of electric energy for charging batteries and for supplying of all DC consumers on board the passenger coach. It is powered by any of four UIC voltages. Switching to another UIC system is performed automatically, without supervision. Modular design enables easy access and low maintenance costs.



Battery charger module

Features

- Four input voltages i.e. supply systems
- Microprocessor control and diagnostics
- Input / output galvanic insulation
- Easy maintenance
- Modular design
- Flat-battery power supply
- Disconnecting and earthing device integrated inside the converter enclosure
- Automatic switching to another input voltage i.e. supply system

KONTRAC PN6MS consists of

- Disconnecting and earthing device
- Input contactors
- Input filter
- High-voltage converter
- Battery charger and module with reactors
- Flat battery power supply
- Control unit

KONTRAC PN6MS

Digital control unit

Digital control unit (DCU) is based on proprietary embedded control platform which has been used for years in our rail solutions (locomotives, coaches, tramways, EMUs, DMUs).

DCU is responsible for all sequence control, regulation, protection, communication, supervision and diagnostics tasks.

Diagnostic and visualization

Proprietary powerful diagnostic and visualization tool (ZZT) is compatible with all our platforms through many generations of control electronic solutions. Configurable event-driven data logging and event recording is integrated in the control electronics.

Mechanical design and cooling system

The converter is designed for under-floor mounting with IP54 protection. Modular design of the converter allows an easy maintenance access enabling easy replacement of each power module. The increased power density of the power modules enables compact and light-weighted converter design. The converter is efficiently cooled by natural convection.

Application example

As a part of modernization of passenger coaches for local transport, passenger coaches series Bee 20-00 and 29-00 have been equipped with multi-system battery charger KONTRAC PN6MS. The converter is used for supplying of all DC consumers onboard the coach as well as for charging coach battery.

BASIC TECHNICAL DATA

Input voltage	1000 / 1500 V, 16-51 Hz 1500 / 3000 Vdc
DC output	30 VDC, 6 kW
Cooling	Natural convection
Size (L x W x H)	1 st Cabinet 1940 x 895 x 580 mm 2 nd Cabinet 920 x 535 x 560 mm
Weight	300 kg
Mounting place	Under-floor
Connecting interface	CAN / MVB / Ethernet



Modernized passenger coach series Bee 29-00 for local passenger transport in Croatia.

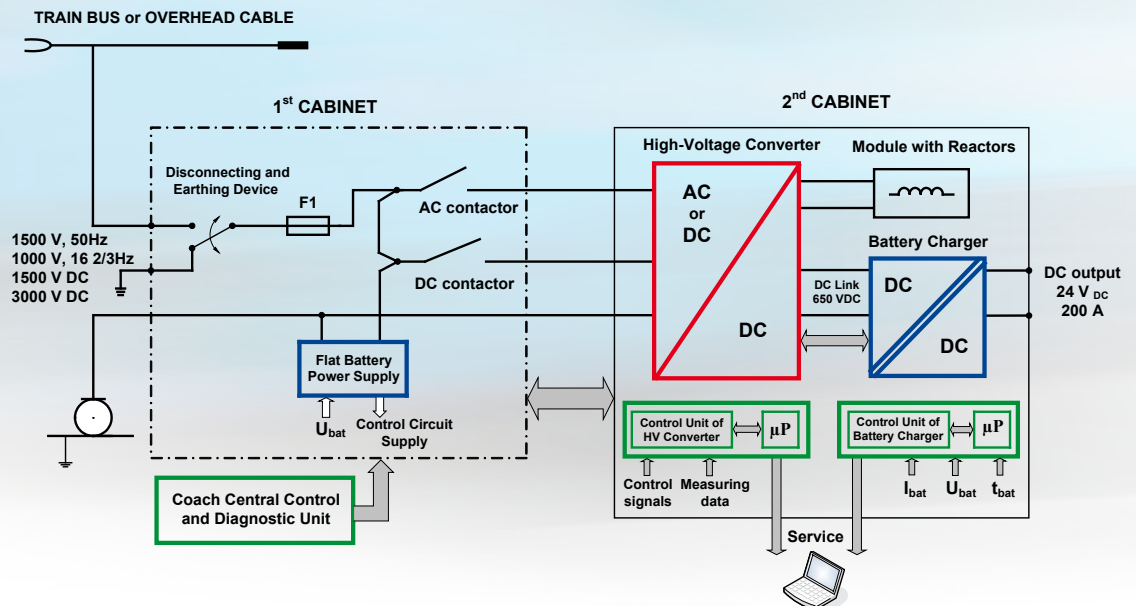

Block diagram of the converter

KONČAR

KONČAR - Electronics and Informatics Inc.

Fallerovo šetalište 22, 10000 Zagreb, Croatia
 phone: +385 1 3655 599; fax: +385 1 3655 298
 e-mail: transportation@koncar-inem.hr
 www.koncar-inem.hr